

Datasheet – SFC6000D, SFM6000D

Best price-performance ratio Mass Flow Controller, Flow Meter



SFC6000D



SFM6000D

Highlights

- Disruptive design with integrated electronics
- High accuracy/repeatability (2% / 0.2% set point)
- Wide control range (500:1)
- RS485 and I²C digital interface
- No drift and no re-calibration required
- Ultra-fast settling time (100 ms)

The heart of SFC6000D and SFM6000D is the unsurpassed Sensirion CMOSens® technology. It combines a high precision sensor element with state-of-the-art signal processing on a single chip and thereby providing an accurately calibrated and temperature compensated signal. In fact, the full functionality of the device is integrated directly on the dedicated ASIC chip, which drastically limits the number of electrical components used. Thanks CMOSens® sensor technology, Sensirion’s flow meters and controllers achieve unmatched ratings for speed, accuracy and repeatability at very attractive system cost. Due to the excellent long-term stability of CMOSens® chips, no recalibration is required.

Device Overview (Page 14: Full product list)

Product	Variant	Description
SFC6000D-	5 slm	High performance, low cost mass flow controller with multi-gas calibration.
	20 slm	
	50 slm	
SFM6000D-	5 slm	High performance, low cost mass flow meter with multi-gas calibration.
	20 slm	
	50 slm	

High performance and low cost of SFC6000D and SFM6000D make them the best choice for a wide range of applications, such as gas flushing, FOUP, analytical instrumentation, coating and medical equipment, process automation and gas mixing to name a few. CMOSens® SFC6000D and SFM6000D measure gas mass flow by the calorimetric principle based on heat transfer. A heater element on a thermally insulated membrane and two thermopiles up-stream and downstream are integrated on a single silicon chip. In the presence of gas flow, the temperature distribution up- and downstream is disturbed. This asymmetry is then measured. The measurement area as well as the A/D-converter and further signal processing are based on a single chip using CMOS standard processes (see Figure 1). Moreover, the same chip also takes over the function of a microprocessor in a standard mass flow controller, directly regulating the valve. This drastically reduces the complexity and the number of electronic components in SFC6000D.

MEMS-based CMOSens® technology enables a significantly larger cross section of the gas channel than bypass capillary diameter in conventional mass flow controllers. This channel design makes the device more robust against particles, clogging and humidified gases.

The minimal thermal mass of the membrane results in an ultra-fast sensor response time of 3-4 ms. Since the whole design of the amplification, A/D conversion, digital linearization and temperature compensation is matched to the sensor speed, a fully compensated flow measurement value can be delivered every millisecond. Combined with advanced control algorithms, SFC6000D offers greatly reduced settling times compared to conventional mass flow controllers.

Furthermore, a special arrangement of the two temperature sensors, on-chip temperature compensation and the minimization of noise sources lead to unbeatable performance with regards to repeatability and accuracy over a large dynamic range. Thanks to the unique CMOSens® technology, the SFC6000D mass flow controllers and SFM6000D mass flow meters show zero-drift performance and control true mass flow independently of the ambient temperature and pressure changes.

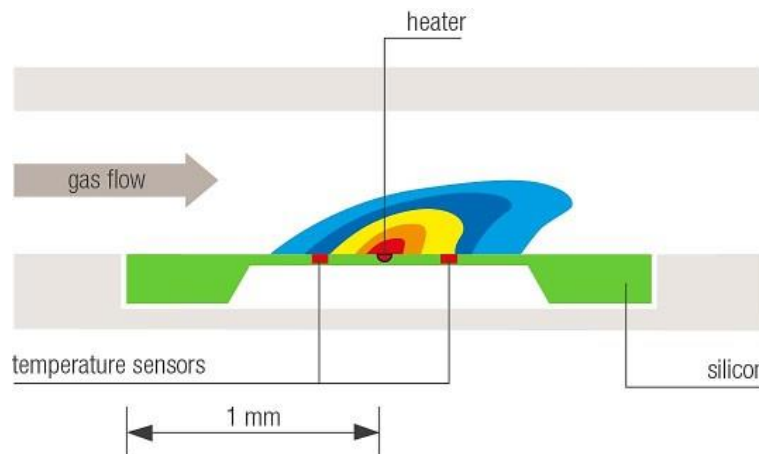

Figure 1. Cross-section view of the gas channel.



Scan me to [provide feedback](#)

1 Quick Start Guide

SFC6000D and SFM6000D can be evaluated easily using the EK-F5x evaluation kit. EK-F5x is compatible with all Sensirion mass flow meters and controllers of 5000 and 6000 families. A quick start guide is included in EK-F5x and can also be found on Sensirion website for the flow meter and mass flow controller.



Figure 2. EK-F5x is the fastest way to evaluate Sensirion flow meters and controllers of 5000 and 6000 families.

2 Sensor Specifications

Specification		Air & N ₂ *	O ₂	CO ₂ *	N ₂ O	Ar
Calibrated gas number		1 (default)	0	2	3	4
Full scale flow [slm]	SFX6000D-5slm	5	5	2	2	2
	SFX6000D-20slm	20	20	10	10	10
	SFX6000D-50slm	50	50	20	20	20
Accuracy ¹ whichever is greater	[% set point]	2.0	2.5	2.0	3.0	3.0
	[% full scale]	0.20	0.25	0.20	0.30	0.30
Repeatability whichever is greater	[% set point]	0.20				
	[% full scale]	0.02				
Specification	Flow range			Unit		
	5 slm	20 slm	50 slm			
Typical setting time ² (SFC only)		100			ms	
Measurement frequency		1000			Hz	
Control / measurement range (SFC / SFM)		0.2% - 100% full scale (500:1)				
Operating temp. (ambient & gas)		5 – 50 / 41 – 122			°C / °F	
Warming up time ³		1 (during the first 5 minutes the accuracy may be below specifications)			s	
Maximum inlet overpressure		10 / 145			bar / psig	
Maximum differential pressure ⁴	SFC6000D	7 / 102	5.5 / 80	4.0 / 58	bar / psig	
	SFM6000D	non applicable				
Pressure drop at full flow N ₂ / Air	SFC6000D	2.0 / 29	2.0 / 29	3.5 / 51	bar / psig	
	SFM6000D	0.01 / 0.15	0.05 / 0.75	0.15 / 2.2		
Supplied fittings		Push-in: tube outer diameter 6 mm (mounted) Downmount (exchangeable with Festo QSP 18 mm interface)				
Interface		Digital: RS 485 and I ² C				
Flow units		slm				

Table 1. Overview of CMOSens® SFC6000D Mass Flow Controller and SFM6000D Mass Flow Meter

Specifications. X stands for C=controller, or M=Meter. All data, unless otherwise noted, apply for the following calibration conditions: Temperature 20°C, Air and horizontal mounting position. SFC is calibrated at 3.0 bar overpressure (inlet: 4.0 bar absolute) against atmosphere (outlet: 1.0 bar absolute). SFM – at atmospheric pressure.

*Air/N₂ and CO₂ are used for physical calibration. The other gasses are modelled. The accuracy stated for the modelled gasses is "typical" and cannot be guaranteed.

¹ Including offset, non-linearity and hysteresis. Measured against NIST traceable reference.

² Step answer from 10% to 100% of full scale within ±5% of set point error band.

³ to within ±2 % of setpoint

⁴ Pressure between flow inlet and flow outlet. For availability of higher differential pressure option, please contact Sensirion

2.1 Gas calibration

SFC6000D and SFM6000D are factory-calibrated for multiple gasses. Table 1 lists the available calibrations and the calibration gas numbers saved in internal memory of the device. The desired calibration can be selected by the user. Please see the application notes describing the communication interfaces or quick start guide for instructions on how to activate a desired calibration. These can be found on <http://www.sensirion.com/sfc6000>.

Please note that the maximum flow rate achievable with each MFC is strongly dependent on the gas measured. Table 1 lists the maximum flow rates for all gasses for which the products have been calibrated.

The calibration for Air and N2 is identical. It can be used with both gasses with the same result.

2.2 Accuracy

Accuracy describes how precisely the mass flow controller / meter is able to control / measure flow rate with respect to the absolute flow of a given gas. Accuracy is mostly determined by the quality of the calibration and can be different for each calibration gas.

For example: with mass flow controller set point of 10 slm and a real flow rate measured by an external reference of 10.2 slm, the set point accuracy would be calculated as:

$$Accuracy = \frac{10.2 - 10}{10.2} = 2.0\% \text{ set point}$$

2.3 Repeatability

Unlike accuracy, repeatability is not influenced by calibration quality and is directly related to the build quality of the mass flow controller / meter. It describes how reliably mass flow controller is able to reach a given setpoint (applied repeatably). For mass flow meter, it describes, how reliably the instrument measures the same flow repeatably.

For example: if a mass flow meter measures the absolute flow of 10 slm multiple times and the resulting flow measurement results follow a Gaussian distribution centered around 9.97 slm with 0.02 standard deviation, then the repeatability is calculated as:

$$Repeatability = \frac{0.02}{9.97} = 0.2\% \text{ set point}$$

Generally, for mass flow controllers / meters repeatability is better than accuracy. For mass flow controllers, in applications where an additional calibration or feedback loop exists, it is possible to rely on repeatability rather than accuracy of mass flow controller. One example would be an optimized process, where the setpoint value of mass flow controller is fine-tuned to give the desired outcome. In such case, it is not important that the absolute flow rate is close to the set point – instead, it is important that the optimized set point can be achieved repeatably to give the same process outcome.

Accuracy and repeatability of SFC6000D and SFM6000D devices are dominated by set point error at high flows and by the full-scale error at low flows. Figure 3 demonstrates this.

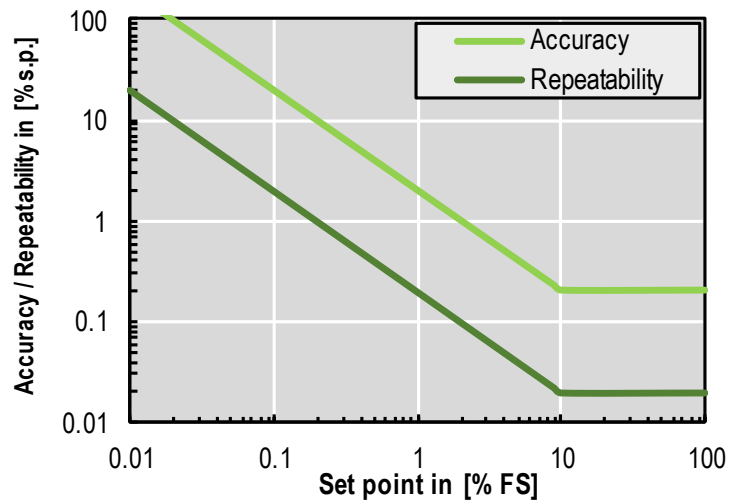

Figure 3. Accuracy and repeatability at different set points. s.p. = set point.

2.4 Settling time

The CMOSens® SFC6000D mass flow controller has an ultra-fast settling time. Figure 4 shows the typical response time of the SFC6000D in comparison to a mass flow controller using conventional capillary technology.

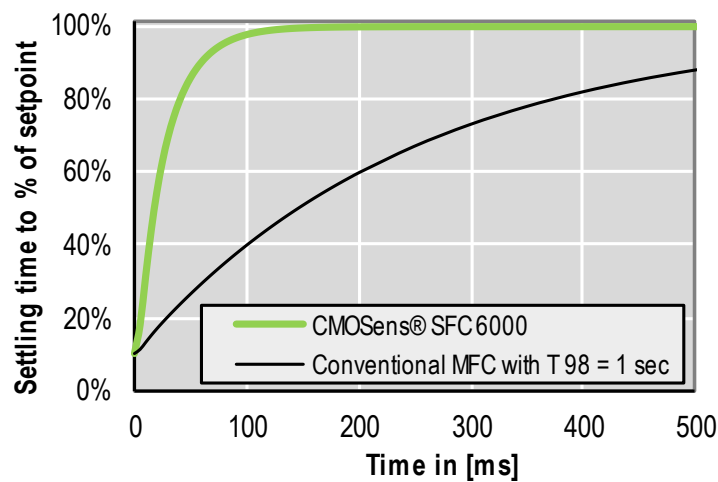

Figure 4. Settling time of the SFC6000D vs. typical thermal mass flow controller.

2.5 Wide control and measurement range

The wide control range of the SFC6000D brings a decisive benefit in applications with a wide dynamic range of gas flows. Instead of two devices used for high flow and low flow ranges, a single SFC6000D device can efficiently cover a flow range of three orders of magnitude.

Control and measurement range is defined as 0.2% - 100% full scale. This means that a mass flow controller with e.g. 50 slm full scale flow, can control flows lower than 0.1 slm. When relying on repeatability rather than absolute accuracy, even lower flows can be controlled.

2.6 Pressure drop

Mass flow controllers need pressurized gas sourced to operate. Pressure drop is generated, when gas passes

through a mass flow controller. When evaluating a mass flow controller, it is important to verify that at maximum required flow rate, for a given gas, the pressure drop will be smaller than the inlet pressure – otherwise the desired maximum flow rate will not be possible to achieve.

Mass flow meters have generally much lower pressure drop due to the absence of the valve and hence this is rarely a practical problem.

Table 1 lists pressure drop at full scale flow of Air or N2. At the same setpoint, for gasses heavier than air, the pressure drop would generally be higher. For gasses lighter than air – it would be lower. Pressure drop scales approximately linearly with the density of the gas.

3 Electrical specifications

Parameter	Min	Typ	Max	Unit
Supply voltage, V_{DD}	22.8	24.0	25.2	VDC
Max current supply SFC6000D	-	210	-	mA
Max current supply SFM6000D	-	20	-	mA
Max standby current	-	< 15	-	mA
Electrical Connector	M8 (4 pin)			

Table 2. Electrical specifications

4 Sensor Operation

SFC6000D and SFM6000D are configured with RS485 and I²C interfaces. Please see the [Technical download \(sensirion.com/sfc6000\)](https://www.sensirion.com/sfc6000) section for instruction on how to use these.

For OEM projects with MOQ of 100 pcs / yr Analog Voltage interface is available on sister platform SFC6000 and SFM6000. Profibus, Modbus and other protocols are available on request.

4.1 RS485 interface

The pinout of the M8 connector available on SFC6000D and SFM6000D is shown below.

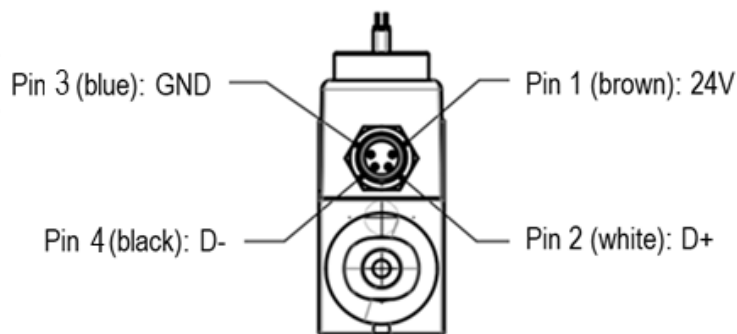

Figure 5. Pinout of M8 connector fitted on SFC6000D and SFM6000D with RS485 interface.

The maximum data readout rate available with RS485 interface is 200 Hz. It is recommended that the cable length between the master and the sensor does not exceed 3m.

EK-F5x evaluation kit is designed to work with RS485 interface. When using the evaluation kit with Windows PC, the highest achievable data readout rate is 20 Hz.

4.2 I2C interface

SFC6000D and SFM6000D can be operated by standard I2C interface. To access I2C interface, please remove the green cap from the sensor and unplug the 6-pin cable inside the sensor. Please make sure that the sensor is not powered, when doing so. Unplugging the internal 6-pin cable, while the device is powered will damage it.

The sensor is equipped with a Molex Micro-Lock Plus connector with 6 circuits and a 1.25 mm pitch (UPC: 889056511957).

An example of a matching cable assembly, is Molex Micro-Lock Plus 0451110606.

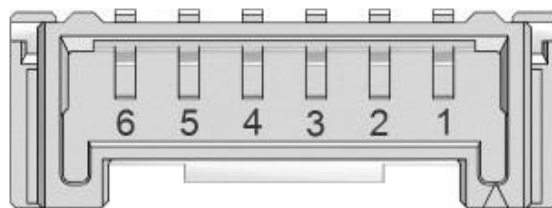

Pin #	Name	Description
1	VDD	Supply Voltage
2	GND	Ground
3	NC	Not Connected
4	SCL	Serial Clock
5	ADDR	I ² C Address Selection
6	SDA	Serial Data

Figure 6. Pinout of 6-pin connector used for I2C communication.

Using I²C interface offers a benefit of faster data readout rates – up to 1 kHz, as compared to 200 Hz with RS485.

4.3 InitStep and Controller gain

The regulation parameters (InitStep and Controller gain) allow fine tuning of the PID controller. They let the user achieve a desired compromise between speed, overshoot, and control stability. The configured gain and initstep are reset upon unplugging the device.

4.3.1 InitStep

InitStep refers to a normalized initial valve voltage. This voltage value will be added to the valve control value if the regulator is in the normal regulation mode and a setpoint value unequal zero is specified. This normalized InitStep value reflects the fact that for instance a 24 V valve starts to open only if the valve voltage is higher than several volts. The customer has the possibility to change this value. Setting a higher InitStep will result in a faster controller but may lead to overshoots. A lower value will result in a smoother opening behavior but may lead to a slower response. The ideal InitStep depends on input pressure and temperature. Please note,

InitStep value is stored in volatile memory and will be reset to the factory value, after the device is unplugged or reset.

4.3.2 Controller gain

The Controller gain refers to a normalized gain parameter, which is set to 1 by default. This gain factor will be multiplied to the control deviation, which is the difference between desired setpoint and measured value, and a correction of the valve control voltage will be applied depending on this control deviation value. If the customer gain factor is increased, this results in a larger change in the output for a given change in the control deviation.

A too low Controller gain value results in a smaller output response to a large input control deviation and therefore to a less responsive / slower controller. On the other hand, if the Controller gain is too high, the system can become unstable: show oscillations and overshoots. As the valve characteristics depend for instance on pressure, the control action may be too strong when responding to system disturbances at high pressures. Therefore, a smaller gain factor may be advisable at higher pressures and the customer has the possibility to tune this parameter according to his conditions and requirements. Please note, that it is also possible to set Controller gain values smaller than 1.

5 Physical Specification

5.1 Fittings

SFC6000D and SFM6000D are factory-fitted with 6 mm push-in fittings (QSPK18-6). These fittings can be safely removed to reveal Festo QSP-type mounting slot. Any compatible QSP fittings can be installed without impacting the performance of the device.

Please note that the supplied QSP push-in fittings are not compatible with O₂-rich gasses due to the grease used. To use your device with O₂-rich gasses, please replace factory-installed fittings on SFC6000D and SFM6000D with the downmount flange provided. When using third-party fittings, please make sure the substitute is compatible with the gas you want to use.

For an example list of compatible fittings and the instructions on how to replace them, please see the application note at [Technical download \(sensirion.com/sfc6000\)](https://www.sensirion.com/technical-download/sfc6000). Other custom-made fittings are available from Sensirion for OEM projects.

5.2 Wetted materials & compatibility

Table 3 gives an overview of the materials wetted by the gas. For high volume OEM applications different specialized materials for the body, valve and sealing can be used with sister products, SFC6000 and SFM6000.

Parameter		
Wetted materials	Flow body and flow sensor	PA12 Si, Si3N4, SiOx Epoxy Glass-filled epoxy Stainless steel FKM
	Valve	Stainless steel FKM PTFE
	Push-in fittings	PA NBR Grease (not O ₂ -compatible)
	Downmount fittings	PA12 FKM
	Flow channel is free of silicone and copper	
REACH, RoHS	REACH and RoHS compliant	

Table 3. Overview of wetted materials

5.3 Safety instructions

5.3.1 Oxygen-rich gases

Most push-in fittings are not compatible with O₂-rich gasses (more than 21% O₂) due to the grease used. This is also the case with the factory-provided QSP push-in fittings on SFC6000D and SFM6000D. At elevated pressures and temperatures, there is a risk of self-ignition of the grease. To use your device with O₂-rich gasses, please use the downmount flanges included or install other O₂-compatible fittings.

5.3.2 Toxic gases

Due to relatively high leakage rate of the push-in connectors, the sensors are not suitable for operation with toxic gasses. If the connectors are replaced, the whole gas assembly must be checked for leakage before applying toxic gas to the device.

5.3.3 Aggressive or corrosive gases

Please make sure that the gases used are compatible with the wetted materials listed in this chapter. In case of doubt, please contact Sensirion for further advice. Corrosive gasses can damage the sealing or the CMOSens® chip.

5.3.4 Flammable gases

SFC6000D and SFM6000D are not designed to be operated with flammable gasses. Please check SFC5xxx and SFM5xxx series to use such gasses.

5.4 Physical dimensions and mounting information

Physical dimensions and mounting information are shown below. The flexible cable between the valve and the green housing can add around 4-6 mm to the total height of SFC6000D.

It is recommended to mechanically fix the sensor during measurement. This will avoid movement of the device and flow disturbances.

The sensor can be mounted from below with PT screws: size K30, max. depth inside housing: 6mm. Alternatively, it can be mounted from the side, using the through-holes. Finally, SFC6000D has two M2.5 mounting slots below the valve – these can be used to fix the sensor from above but require a (temporary) removal of the green cap. Downmount fittings available with SFC6000D and SFM6000D offer additional mounting holes.

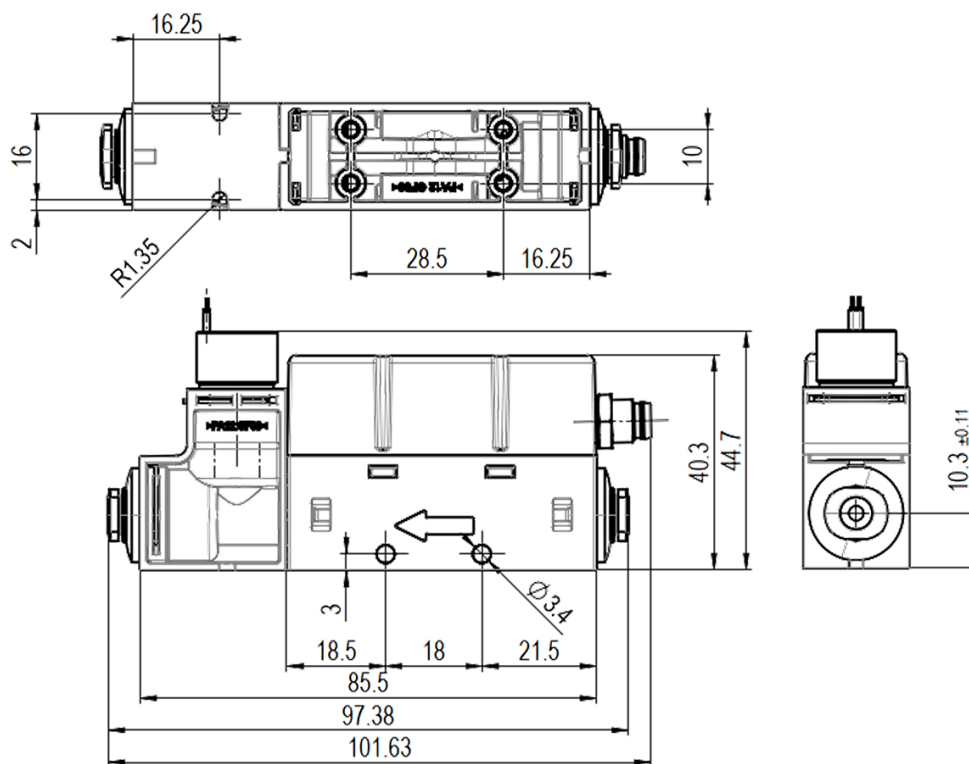

Figure 7. Physical dimensions and mounting information for SFC6000D with push-in fittings. All units are in [mm].

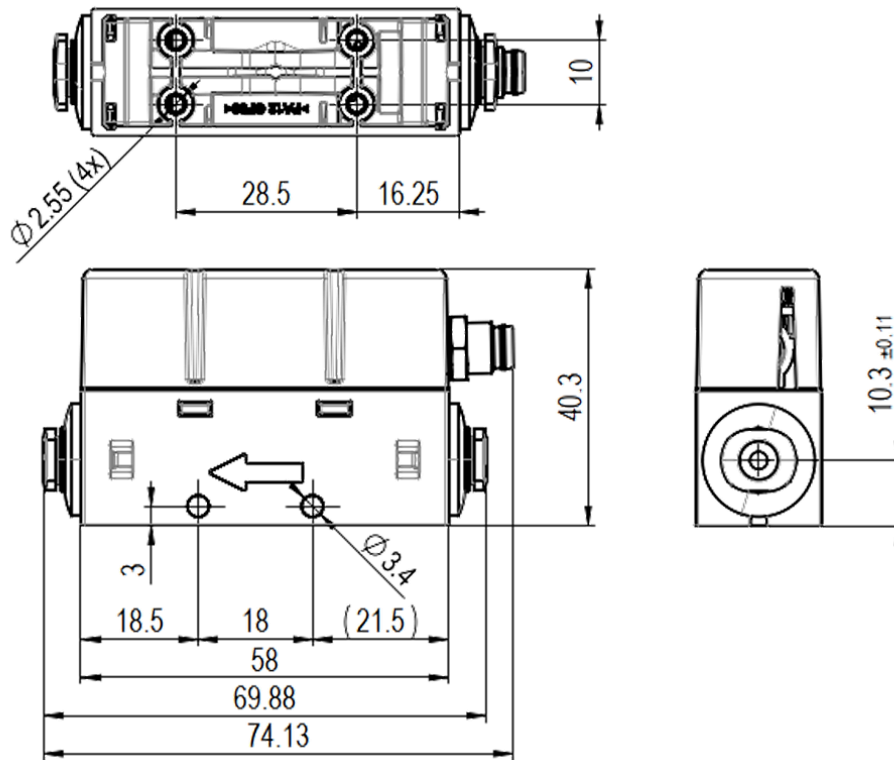

Figure 8. Physical dimensions and mounting information for SFM6000D with push-in fittings. All units are in [mm].

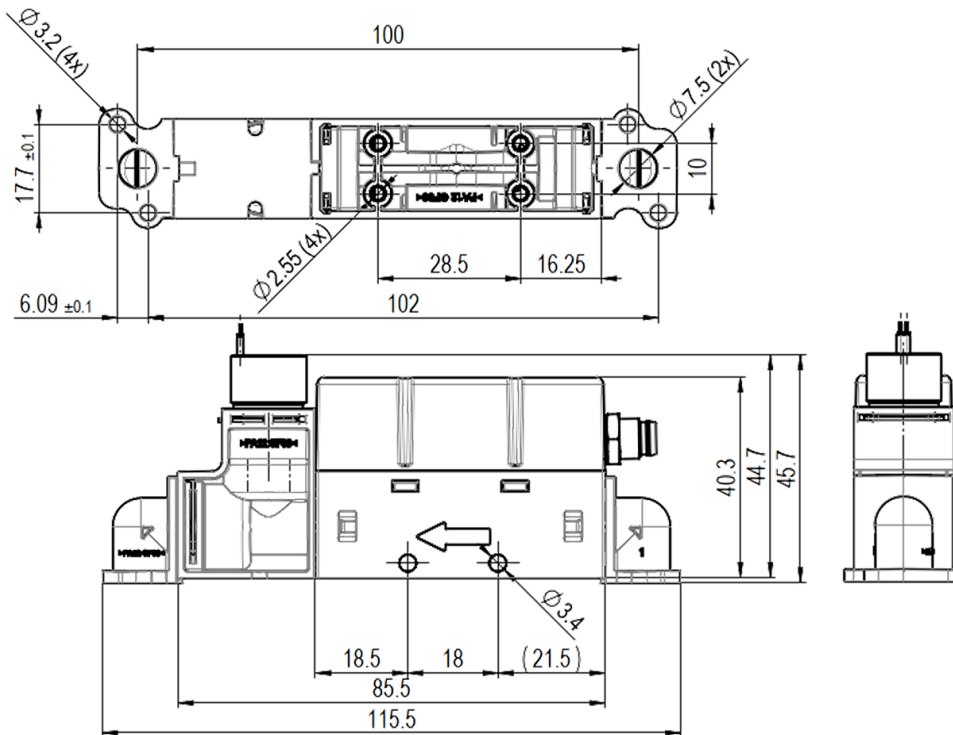

Figure 9. Physical dimensions and mounting information for SFC6000D with downmount fittings. All units are in [mm].

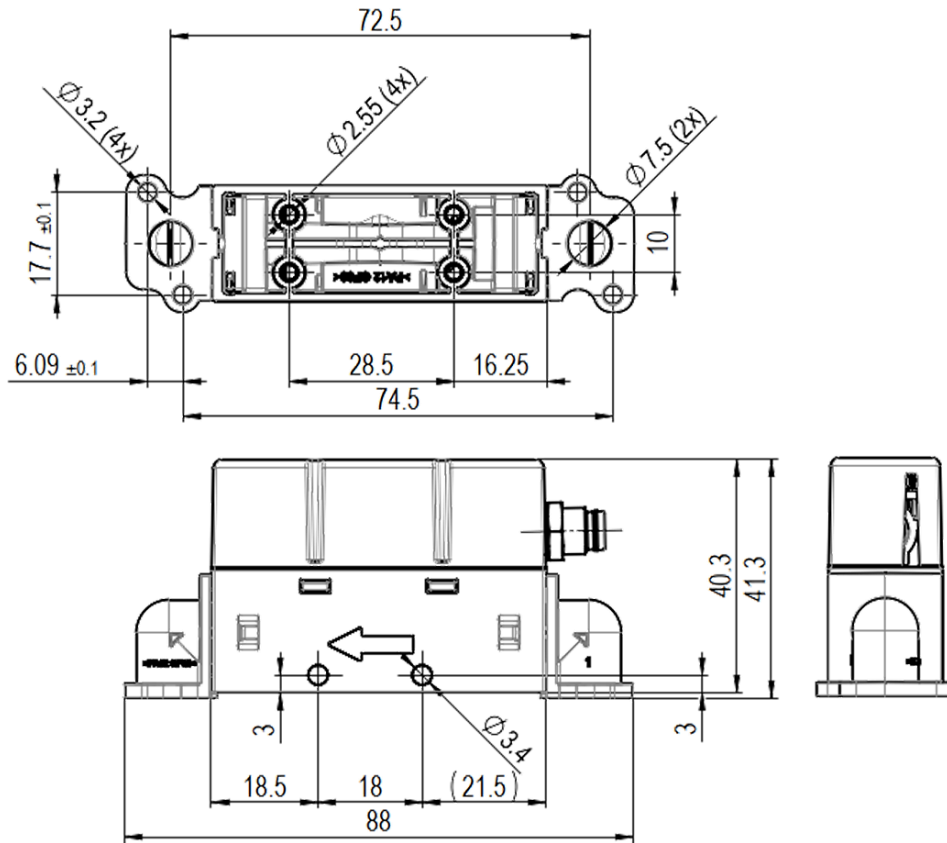

Figure 10. Physical dimensions and mounting information for SFM6000D with downmount fittings. All units are in [mm].

6 Flow units

SFC6000D and SFM6000D are calibrated in “standard units” – namely slm (standard liter per minute). Table 4 lists other common units used for measuring gas flow and a relationship between them. If your device appears to show c.a. 7% error vs your reference, it is possible the reference is displaying flow in “norm” units.

Flow unit	Reference condition	
	Gas Temperature	Gas Pressure
slm (standard liter per minute)	20 °C / 68° F	1013 mbar / 14.69 psi
In/min (norm liter per minute)	0 °C / 32° F	

Table 4. Common units used to express gas flow rates.

Example:

$$10 \text{ slm (20°C / 68°F, 1013 mbar)} = 9.32 \text{ In/min (0°C, 1013 mbar)}$$

7 OEM options

SFC6000D and SFM6000D mass flow controllers / meters are all special versions of Sensirion’s SFC6000 and SFM6000 platform. SFC6000D and SFM6000D were designed as distribution products to meet a wide range of needs. In case SFC6000D or SFM6000D does not meet exactly the requirements for a given application, Sensirion recommends looking at SFC6000 and SFM6000 mass flow controllers / meters, which are available with a variety of configurations (fittings, flow ranges, calibrations, interfaces) and are generally built on order. These devices are available directly from Sensirion with a minimum order quantity (MOQ) of 100 pcs. SFC6000 and SFM6000 also allow for OEM product development in the context of high-volume projects. Possibilities involve different communication interfaces, wetted materials and gas calibrations.

8 Ordering Information

Article	Description	Article number
SFC6000D-5slm	Digital mass flow controller 5 – 0.01 slm flow range	3.000.900
SFC6000D-20slm	Digital mass flow controller 20 - 0.04 slm flow range	3.000.901
SFC6000D-50slm	Digital mass flow controller 50 - 0.1 slm flow range	3.000.902
SFM6000D-5slm	Digital mass flow meter 5 – 0.01 slm flow range	3.000.897
SFM6000D-20slm	Digital mass flow meter 20 - 0.04 slm flow range	3.000.898
SFM6000D-50slm	Digital mass flow meter 50 - 0.1 slm flow range	3.000.899
EK-F5x	Plug-and-play evaluation kit (without mass flow meter / controller)	3.000.912

Table 5. Products in SFC6000D and SFM6000D series and a compatible evaluation kit

9 Revision History

Date	Version	Pages	Changes
Mar 2023	1.0	all	Initial version

Important Notices

Warning, Personal Injury

Do not use this product as safety or emergency stop devices or in any other application where failure of the product could result in personal injury. Do not use this product for applications other than its intended and authorized use. Before installing, handling, using or servicing this product, please consult the data sheet and application notes. Failure to comply with these instructions could result in death or serious injury.

If the Buyer shall purchase or use SENSIRION products for any unintended or unauthorized application, Buyer shall defend, indemnify and hold harmless SENSIRION and its officers, employees, subsidiaries, affiliates and distributors against all claims, costs, damages and expenses, and reasonable attorney fees arising out of, directly or indirectly, any claim of personal injury or death associated with such unintended or unauthorized use, even if SENSIRION shall be allegedly negligent with respect to the design or the manufacture of the product.

ESD Precautions

The inherent design of this component causes it to be sensitive to electrostatic discharge (ESD). To prevent ESD-induced damage and/or degradation, take customary and statutory ESD precautions when handling this product. See application note "ESD, Latchup and EMC" for more information.

Warranty

SENSIRION warrants solely to the original purchaser of this product for a period of 12 months (one year) from the date of delivery that this product shall be of the quality, material and workmanship defined in SENSIRION's published specifications of the product. Within such period, if proven to be defective, SENSIRION shall repair and/or replace this product, in SENSIRION's discretion, free of charge to the Buyer, provided that:

- notice in writing describing the defects shall be given to SENSIRION within fourteen (14) days after their appearance;
- such defects shall be found, to SENSIRION's reasonable satisfaction, to have arisen from SENSIRION's faulty design, material, or workmanship;
- the defective product shall be returned to SENSIRION's factory at the Buyer's expense; and
- the warranty period for any repaired or replaced product shall be limited to the unexpired portion of the original period.

This warranty does not apply to any equipment which has not been installed and used within the specifications recommended by SENSIRION for the intended and proper use of the equipment. EXCEPT FOR THE WARRANTIES EXPRESSLY SET FORTH HEREIN, SENSIRION MAKES NO WARRANTIES, EITHER EXPRESS OR IMPLIED, WITH RESPECT TO THE PRODUCT. ANY AND ALL WARRANTIES, INCLUDING WITHOUT LIMITATION, WARRANTIES OF MERCHANTABILITY OR FITNESS FOR A PARTICULAR PURPOSE, ARE EXPRESSLY EXCLUDED AND DECLINED.

SENSIRION is only liable for defects of this product arising under the conditions of operation provided for in the data sheet and proper use of the goods. SENSIRION explicitly disclaims all warranties, express or implied, for any period during which the goods are operated or stored not in accordance with the technical specifications.

SENSIRION does not assume any liability arising out of any application or use of any product or circuit and specifically disclaims any and all liability, including without limitation consequential or incidental damages. All operating parameters, including without limitation recommended parameters, must be validated for each customer's applications by customer's technical experts. Recommended parameters can and do vary in different applications.

SENSIRION reserves the right, without further notice, (i) to change the product specifications and/or the information in this document and (ii) to improve reliability, functions and design of this product.

Headquarters and Subsidiaries

Sensirion AG

Laubisruetistr. 50
CH-8712 Staefa ZH
Switzerland

phone: +41 44 306 40 00
fax: +41 44 306 40 30
info@sensirion.com
www.sensirion.com

Sensirion Taiwan Co. Ltd

phone: +886 2 2218-6779
info@sensirion.com
www.sensirion.com

Sensirion Inc., USA

phone: +1 312 690 5858
info-us@sensirion.com
www.sensirion.com

Sensirion Japan Co. Ltd.

phone: +81 45 270 4506
info-jp@sensirion.com
www.sensirion.com/jp

Sensirion Korea Co. Ltd.

phone: +82 31 337 7700~3
info-kr@sensirion.com
www.sensirion.com/kr

Sensirion China Co. Ltd.

phone: +86 755 8252 1501
info-cn@sensirion.com
www.sensirion.com/cn

To find your local representative, please visit
www.sensirion.com/distributors